

FlowCon Green.0 / Green.1 / Green.2

Pressure Independent Control Valves
15-40 mm / 1/2"-1 1/2"



SPECIFICATIONS

Insert:

Static pressure:	2500 kPa / 360 psi
Ambient temperature:	+1°C to +50°C / +34°F to +122°F
Media temperature ¹ :	-20°C to +120°C / -4°F to +248°F
Material:	
- Insert:	Glass-reinforced PSU/POM/PPS
- Metal components (internal):	Stainless steel
- O-rings:	EPDM
- Cone:	PPS
- Diaphragm:	20 mm / 3/4" insert: EPDM 40 mm / 1 1/2" insert: Hydrogenated acrylonitrile-butadiene-rubber
- Head nut:	Forged brass ASTM CuZn40Pb2
Stroke:	20 mm / 3/4" insert: 3.4 mm / 0.13 in 40 mm / 1 1/2" insert: 5.2 mm / 0.2 in
Maximum close off pressure:	800 kPa / 116 psi
Maximum operational ΔP:	800 kPaD / 116 psid
Control characteristic:	linear (may be converted to equal % on actuator)
Control range:	1:1000 / IEC 60534
Rangeability:	100:1
Turn down ratio:	100:1
Shut-off leakage:	ANSI / FCI 70-2 2006, Class IV / IEC 60534-4, Class IV
Flow rate range:	20 mm / 3/4" insert: 0.0103-0.736 l/sec / 0.163-11.7 GPM 40 mm / 1 1/2" insert: 0.240-1.29 l/sec / 3.81-20.4 GPM

Valve:

Material:	
- Housing:	Forged brass ASTM CuZn40Pb2 or DZR ASTM CuZn36Pb2As
- Ball valve:	ABV: Chemically nickel plated brass ball
End connections ² :	A/AB: Fixed female ISO or NPT ABV: Union end connection in brass alloy ISO or NPT
Housing taps:	AB/ABV: 1/4" ISO.

Note 1: Stated temperature rating is defined due to no external insert condensation.
Note 2: NPT only available ex. US-factory.

SPECIFICATIONS (...continued)

FlowCon Actuators:

FlowCon Actuator ²	FT.0.2 ³	FT.0.3 ³	FT.0.4 ³
Supply voltage	24V AC -10%... +20%, 50/60Hz	230V AC ±10%, 50/60Hz	24V AC/DC -10%... +20%, 50/60Hz
Type	Thermal	Thermal	Thermal
Power consumption	1.2W	1.2W	1.2W
Control signal	Analog 0-10V, Normally closed	ON/OFF, Normally closed	ON/OFF, Normally closed
Failsafe function	Yes	Yes	Yes
Operation time ⁴	App. 3.5 minutes	App. 4.5 minutes	App. 4.5 minutes
Ambient temperature	0°C to +60°C / +32°F to +140°F	0°C to +60°C / +32°F to +140°F	0°C to +60°C / +32°F to +140°F
Protection	IP54 including upside-down, class III	IP54 including upside-down, class II	IP54 including upside-down, class III
Cable	Plug-in, 1 m / 3 ft	Fixed, 1 m / 3 ft	Fixed, 1 m / 3 ft
Weight	0.12 kg / 0.26 lb	0.11 kg / 0.24 lb	0.11 kg / 0.24 lb

Note 2: FlowCon warranty is voided using other actuators than supplied by FlowCon International.

Note 3: Please note if mounted on FlowCon Green.2 specified leakage rate to be exceeded.

Note 4: Closing time is approximately the double dependent on ambient temperature.

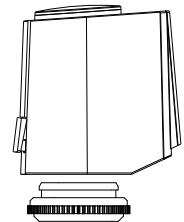

FlowCon FT.0.2

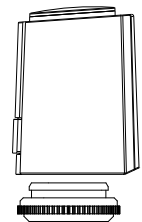

FlowCon FT.0.3/0.4

FlowCon Actuator ⁵	FN.0.2	FN.0.3	FN.0.4
Supply voltage	24V AC/DC ±10%, 50/60 Hz	110/230V AC ±10%, 50/60 Hz	24V AC/DC ±10%, 50/60 Hz
Type	Electrical, bi-directional synchronous motor		
Power consumption	AC: 2.5VA operating (4.7VA max) DC: 1.2W operating (2.2W max)	5VA	AC: 2.5VA operating (4.7VA max) DC: 1.2W operating (2.2W max)
Control signal	Analog 0(2)-10V DC, <0.5mA	Digital 2-position / 3-point floating	Digital 2-position / 3-point floating
Feedback	Yes, control signal	No	No
Failsafe function	No	No	No
Auto stroke	Yes	No	Yes
Operation time	max 22 sec/mm	50 Hz: 18.5 sec/mm	max 22 sec/mm
Ambient temperature	0°C to +50°C / +32°F to +122°F	+2°C to +50°C / +36°F to +122°F	0°C to +50°C / +32°F to +122°F
Media temperature	0°C to +120°C / +32°F to +248°F	-	0°C to +120°C / +32°F to +248°F
Humidity rating	0..85% rH, no condensation	<95% rH, no condensation	0..85% rH, no condensation
Protection	IP54, class III (IP40 upside-down) indoor use only	IP54, class II	IP54, class III (IP40 upside-down) indoor use only
Cable	Fixed 5 x 0.5 mm ² , 1.5 m / 5 x AWG20, 4.9 ft	Fixed 3 x 0.3 mm ² , 1 m halogen free / 3 x AWG22, 3 ft halogen free	Fixed 3 x 0.5 mm ² , 1.5 m 3 x AWG20, 4.9 ft
Closing point adjustment	During operation the actuator will self-adjust according to the closing point of the valve		
Weight	0.25 kg / 0.55 lb	0.25 kg / 0.55 lb	0.25 kg / 0.55 lb

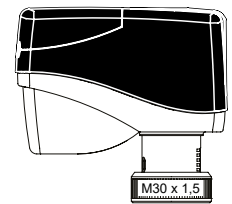

FlowCon FN.0.2/0.4/1.2

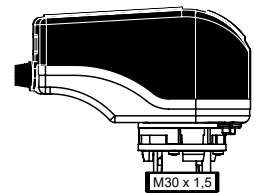

FlowCon FN.0.3

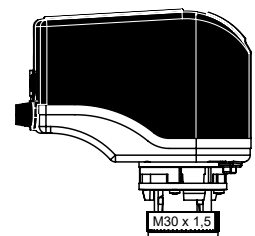

FlowCon FN.1.4

Note 5: FlowCon warranty is voided using other actuators than supplied by FlowCon International.

FlowCon Actuator ⁶	FN.1.2	FN.1.4
Supply voltage	24V AC/DC ±10%, 50/60 Hz	
Type	Electrical, bi-directional synchronous motor	
Power consumption	AC: 5.8VA operating (6.8VA max) DC: 2.9W operating (3.3W max)	6VA, 10VA peaks
Control signal	Analog 0(2)-10V DC, <0.5mA	Digital 2-position
Feedback	Yes, control signal	No
Failsafe function	Yes	Yes
Auto stroke	Yes	No
Operation time	22 sec/mm (failsafe mode: 5 sec/mm)	50 Hz: 18.5 sec/mm
Ambient temperature	0°C to +50°C / +32°F to +122°F	+2°C to +50°C / +36°F to +122°F
Media temperature	0°C to +120°C / +32°F to +248°F	-
Humidity rating	0..85% rH, no condensation	<95% rH, no condensation
Protection	IP54, class III (IP40 upside-down) indoor use only	IP54, class II
Cable	Fixed, 5 x 0.5 mm ² , 1.5 m / 5 x AWG20, 4.9 ft	Fixed, 4 wires AWG22 halogen free cable, 1 m / 3 ft
Closing point adjustment	During operation the actuator will self-adjust according to the closing point of the valve	
Weight	0.27 kg / 0.60 lb	0.30 kg / 0.66 lb

Note 6: FlowCon warranty is voided using other actuators than supplied by FlowCon International.

DIMENSIONS AND WEIGHT (NOMINAL)

Model no.	Valve model	Valve size mm (in)	Insert size mm (in)	L mm (in)	H1 mm (in)	H2 FT.0.2 actuator mm (in)	H3 FT.0.3/0.4 actuator mm (in)	H4 FN.0.2/0.4 actuator mm (in)	H5 FN.0.3 actuator mm (in)	H6 FN.1.X actuator mm (in)	End connections C7			Weight ⁸ kg (lb)	Kv/Cv ⁹ m ³ /hr (GPM)
											Female ISO (NPT)	Male ISO (NPT)	Sweat ISO (NPT)		
G.X.XX.04	A	15 (1/2)	20 (3/4)	80 (3.15)	31 (1.22)	118 (4.65)	116 (4.57)	124 (4.88)	130 (5.12)	145 (5.71)	-	-	-	0.54 (1.19)	3.1 (3.6)
G.X.XX.05		20 (3/4)												0.50 (1.10)	
G.X.XX.06		25 (1)												0.54 (1.19)	
G.X.XX.01	AB	15 (1/2)	20 (3/4)	81 (3.19)	31 (1.22)	118 (4.65)	116 (4.57)	124 (4.88)	130 (5.12)	145 (5.71)	-	-	-	0.50 (1.11)	3.6 (4.2)
G.X.XX.02		85 (3.35)		0.52 (1.14)											
G.X.XX.07		102 (4.02)		0.72 (1.59)										3.1 (3.6)	
G.2.XX.14		25 (1)		40 (1 1/2)										128 (5.04)	47 (1.85)
G.2.XX.15	32 (1 1/4)	1.70 (3.75)													
G.X.XX.03	ABV	15 (1/2)	20 (3/4)	122 (4.80)	33 (1.30)	118 (4.65)	116 (4.57)	124 (4.88)	130 (5.12)	145 (5.71)	22 (0.87)	24 (0.95)	20 (0.79)	0.90 (1.98)	3.1 (3.6)
		22 (0.87)									25 (0.99)	20 (0.79)			
		-									39 (1.54)	22 (0.87)			
G.2.XX.17		25 (1)	40 (1 1/2)	162 (6.38)	42 (1.65)	138 (5.43)	137 (5.39)	144 (5.67)	153 (6.02)	165 (6.50)	35 (1.38)	40 (1.57)	34 (1.34)	2.14 (4.72)	11.7 (13.6)
		33 (1.30)									40 (1.57)	34 (1.34)			
		33 (1.30)									42 (1.65)	-			

Note 7: Add end connection length to body length.

Note 8: Weight does not include end connections or actuator.

Note 9: For valve body.

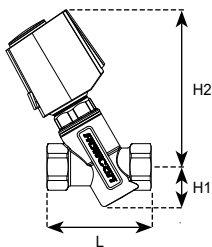

FlowCon Green.0/1 in
FlowCon A valve
DN15/20/25 (1/2", 3/4", 1")
with FlowCon FT.0.2 actuator

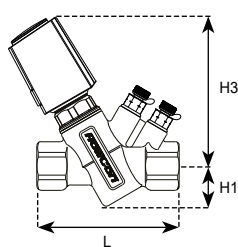

FlowCon Green.0/1 in
FlowCon AB valve
DN15/20/25 (1/2", 3/4", 1")
with FlowCon FT.0.3/0.4 act.

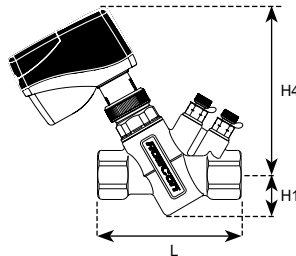

FlowCon Green.0/1 in
FlowCon AB valve
DN15/20/25 (1/2", 3/4", 1")
w. FlowCon FN.0.2/0.4/1.2 actuator

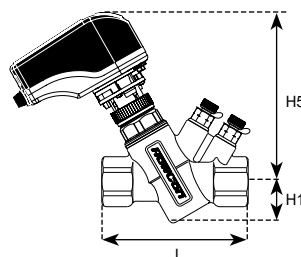

FlowCon Green.0/1 in
FlowCon AB valve
DN15/20/25 (1/2", 3/4", 1")
with FlowCon FN.0.3 actuator

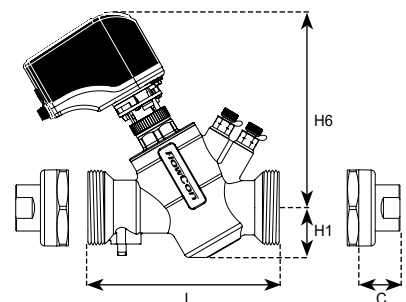

FlowCon Green.2 in
FlowCon ABV2 valve
DN25/32/40 (1", 1 1/4", 1 1/2")
with FlowCon FN.1.4 actuator

MODEL NUMBER SELECTION

Insert flow range:

0=20 mm / 3/4" insert (low flow)
1=20 mm / 3/4" insert (medium flow)
1HF=20 mm / 3/4" insert (high flow)
2=40 mm / 1 1/2" insert

Insert type of actuator:

00=no actuator
22=FT.0.2 **23**=FT.0.3 **24**=FT.0.4
32=FN.0.2 **33**=FN.0.3 **34**=FN.0.4 **42**=FN.1.2 **44**=FN.1.4

Insert type of housing:

20 mm / 3/4" insert: **01**=AB DN15, 1/2"
02=AB DN20, 3/4"
03=ABV1 DN15-25, 1/2"-1"
04=A DN15, 1/2"
05=A DN20, 3/4"
06=A DN25, 1"
07=AB DN25, 1"

40 mm / 1 1/2" insert: **14**=AB DN25, 1"
15=AB DN32, 1 1/4"
17=ABV2 DN25-40, 1"-1 1/2"

Insert p/t plug requirements:

B=pressure/temperature plugs **P**=taps plugged - leave blank if A-body or no p/t plugs required

Insert inlet x outlet union end connections: - leave blank if A- or AB-body or no end connections required

Body model and size	Female threaded	Male treaded	Sweat	
G.0.XX.03, 15-25 mm, 1/2"-1" G.1.XX.03, 15-25 mm, 1/2"-1"	E = 15 mm / 1/2" F = 20 mm / 3/4"	H = 15 mm / 1/2" I = 20 mm / 3/4" J = 25 mm / 1"	K = 15 mm L = 18 mm M = 22 mm	O = 1/2" R = 3/4" U = 1"
G.2.XX.17, 25-40 mm, 1"-1 1/2"	G = 25 mm / 1" P = 32 mm / 1 1/4" Q = 40 mm / 1 1/2"	J = 25 mm / 1" S = 32 mm / 1 1/4" T = 40 mm / 1 1/2"	N = 28 mm W = 35 mm	V = 1 1/4" W = 1 1/2"

Insert connections standard:

I=ISO (standard)

Example: G.1.22.03.B.F.F.I=20 mm (3/4") FlowCon Green, medium flow, with an ABV1-body with p/t plugs and a 24V thermal modulating actuator and DN20 (3/4") ISO female union end connections.

WIRING INSTRUCTION

FlowCon FT (analog)

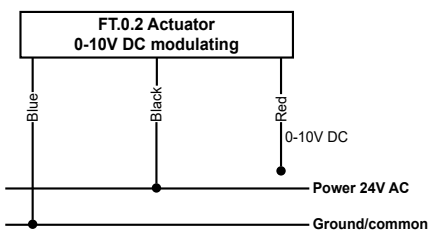

FlowCon FT (digital)

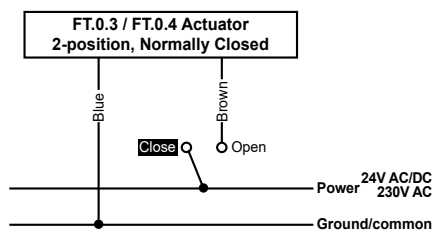

FlowCon FN (analog)

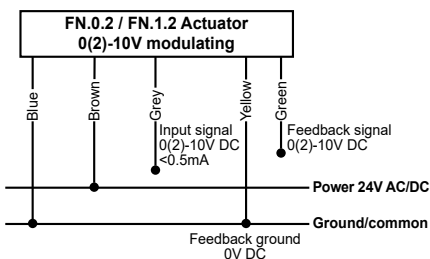

WIRING INSTRUCTION (...continued)

FlowCon FN (digital)

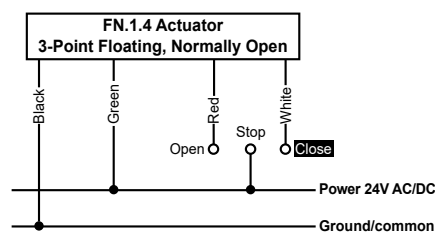
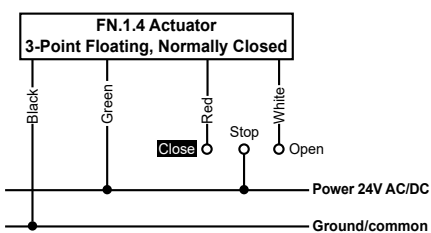
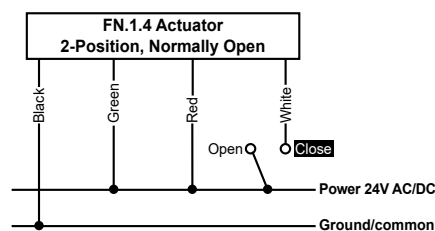
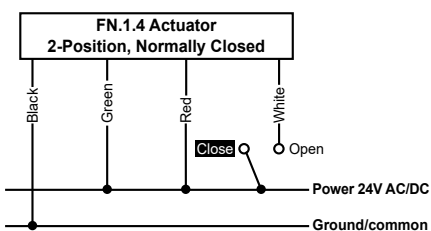
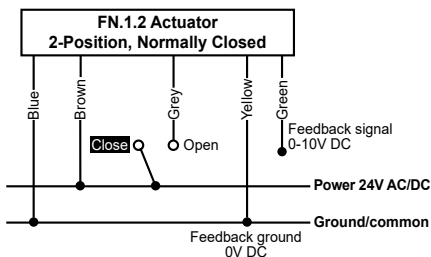
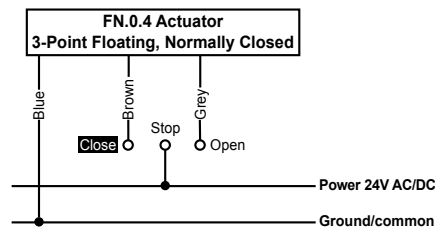
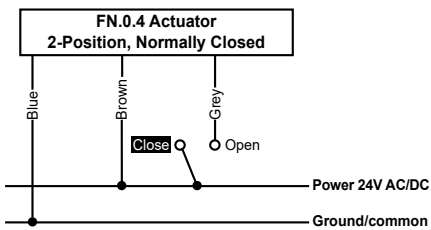
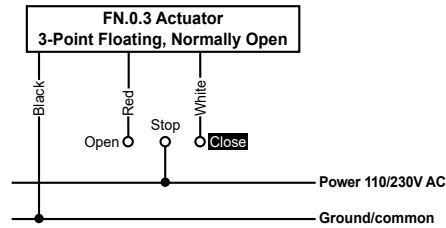
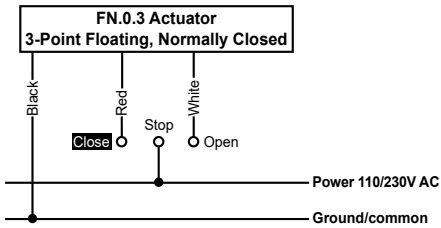
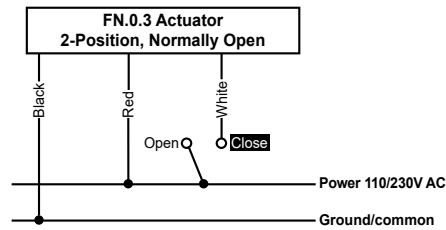
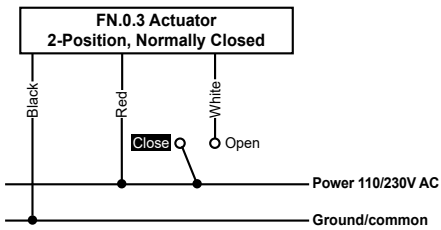

DESCRIPTION

The FlowCon Green series is a range of pressure independent control valves that are two-way, modulating to accept digital or analog input signals. The valves accept 0(2)-10V, 3-point floating or ON/OFF input signals. Each valve has an adjustable maximum flow rate setting maintaining a full stroke to enable flow limitation and balancing to the coil or zone that the valve is controlling.

For use in fan-coil units, VAV applications and cooling ceilings for activation of heating or cooling. They are available in three different valve housings, i.e. FlowCon A, AB or ABV.

MAXIMUM FLOW RATE LIMITATION SETTINGS

FlowCon Green														
Insert size: 20 mm · 3/4"											Insert size: 40 mm · 1 1/2"			Setting
16-600 kPaD · 2.3-87 psid ¹⁰			30-800 kPaD · 4.4-116 psid ¹¹			35-800 kPaD · 5.1-116 psid ¹¹			16-800 kPaD · 2.3-116 psid (at setting: 2.6)					
Green.0 (grey O-ring)			Green.1 (black O-ring)			Green.1HF (black O-ring)			Green.2 (black O-ring)			Setting		
l/sec	l/hr	GPM	l/sec	l/hr	GPM	l/sec	l/hr	GPM	l/sec	l/hr	GPM			
-	-	-	0.0178	64	0.282	-	-	-	0.240	865	3.81	1.0		
0.0103	37	0.163	0.0393	142	0.624	-	-	-	0.282	1010	4.46	1.1		
0.0233	84	0.370	0.0580	209	0.920	-	-	-	0.322	1160	5.10	1.2		
0.0322	116	0.510	0.0743	268	1.180	-	-	-	0.361	1300	5.72	1.3		
0.0419	151	0.664	0.0887	319	1.41	-	-	-	0.399	1430	6.32	1.4		
0.0500	180	0.792	0.102	366	1.61	0.172	620	2.73	0.435	1570	6.90	1.5		
0.0569	205	0.902	0.113	408	1.80	0.200	720	3.17	0.471	1700	7.47	1.6		
0.0650	234	1.03	0.124	446	1.96	0.228	820	3.61	0.506	1820	8.02	1.7		
0.0719	259	1.14	0.134	482	2.12	0.258	930	4.10	0.540	1940	8.56	1.8		
0.0781	281	1.24	0.143	516	2.27	0.294	1060	4.67	0.573	2060	9.08	1.9		
0.0839	302	1.33	0.152	549	2.42	0.325	1170	5.15	0.605	2180	9.59	2.0		
0.0889	320	1.41	0.161	580	2.56	0.350	1260	5.55	0.636	2290	10.1	2.1		
0.0942	339	1.49	0.170	611	2.69	0.375	1350	5.95	0.667	2400	10.6	2.2		
0.0981	353	1.55	0.178	641	2.82	0.396	1430	6.28	0.696	2510	11.0	2.3		
0.103	371	1.63	0.186	671	2.95	0.417	1500	6.61	0.725	2610	11.5	2.4		
0.106	381	1.68	0.194	700	3.08	0.439	1580	6.96	0.753	2710	11.9	2.5		
0.109	394	1.73	0.202	728	3.21	0.458	1650	7.27	0.780	2810	12.4	2.6		
0.113	406	1.79	0.210	756	3.33	0.481	1730	7.62	0.807	2900	12.8	2.7		
0.115	414	1.82	0.218	783	3.45	0.500	1800	7.93	0.832	3000	13.2	2.8		
0.119	428	1.88	0.225	810	3.56	0.522	1880	8.28	0.858	3090	13.6	2.9		
0.122	439	1.93	0.232	835	3.68	0.542	1950	8.59	0.882	3180	14.0	3.0		
0.125	449	1.98	0.239	860	3.79	0.550	1980	8.72	0.906	3260	14.4	3.1		
0.127	458	2.02	0.245	883	3.89	0.558	2010	8.85	0.930	3350	14.7	3.2		
0.130	468	2.06	0.252	906	3.99	0.567	2040	8.99	0.953	3430	15.1	3.3		
0.133	477	2.10	0.257	927	4.08	0.575	2070	9.12	0.975	3510	15.5	3.4		
0.135	486	2.14	0.263	946	4.17	0.583	2100	9.25	0.997	3590	15.8	3.5		
0.137	494	2.17	0.268	965	4.25	0.597	2150	9.47	1.02	3670	16.1	3.6		
0.140	503	2.21	0.273	982	4.32	0.611	2200	9.69	1.04	3740	16.5	3.7		
0.142	511	2.25	0.277	998	4.39	0.625	2250	9.91	1.06	3820	16.8	3.8		
0.144	518	2.28	0.281	1010	4.46	0.639	2300	10.1	1.08	3890	17.1	3.9		
0.146	526	2.31	0.285	1020	4.51	0.653	2350	10.4	1.10	3960	17.4	4.0		
0.148	532	2.34	0.288	1040	4.57	0.661	2380	10.5	1.12	4030	17.7	4.1		
0.149	538	2.37	0.291	1050	4.61	0.669	2410	10.6	1.14	4100	18.1	4.2		
0.151	544	2.39	0.294	1060	4.66	0.678	2440	10.7	1.16	4170	18.4	4.3		
0.153	549	2.42	0.296	1070	4.70	0.686	2470	10.9	1.18	4240	18.7	4.4		
0.154	553	2.43	0.299	1080	4.73	0.694	2500	11.0	1.20	4300	19.0	4.5		
0.155	559	2.46	0.301	1080	4.77	0.703	2530	11.1	1.21	4370	19.2	4.6		
0.156	563	2.48	0.303	1090	4.80	0.711	2560	11.3	1.23	4440	19.5	4.7		
0.158	567	2.50	0.305	1100	4.83	0.719	2590	11.4	1.25	4500	19.8	4.8		
0.159	571	2.51	0.307	1100	4.86	0.728	2620	11.5	1.27	4570	20.1	4.9		
0.160	575	2.53	0.308	1110	4.89	0.736	2650	11.7	1.29	4630	20.4	5.0		

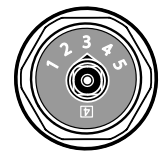

A micrometer **setting of 3.4** as illustrated above corresponds to a maximum flow rate of

Green.0: 0.133 l/sec (2.10 GPM)

Green.1: 0.257 l/sec (4.08 GPM)

Green.2: 0.975 l/sec (15.5 GPM)

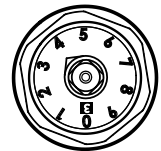

Scale setting for **Green.1HF** is reversed.

A micrometer **setting of 3.4** as illustrated above corresponds to a maximum flow rate of

Green.1HF: 0.575 l/sec (9.12 GPM)

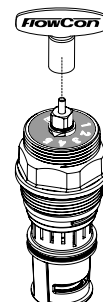

Use the special designed key (FlowCon part no. ACC0001) for micrometer setting.

Accuracy: Greatest of either $\pm 10\%$ of controlled flow rate or $\pm 5\%$ of maximum flow rate.
 Note 10: If used in pressure range 200-600 kPaD (29-87 psid), accuracy of $-20\% / +0\%$ applies.
 Note 11: If used in pressure range 400-800 kPaD (58-116 psid), accuracy of $-20\% / +0\%$ applies.

GENERAL SPECIFICATIONS

1. PRESSURE INDEPENDENT DYNAMIC CONTROL VALVES - FLOWCON GREEN

- 1.1. Contractor shall install the pressure independent dynamic control valves where indicated in drawings.
- 1.2. Valve shall be an electronic, dynamic, modulating, 2-way, pressure independent control device.
- 1.3. Pressure independent dynamic control valve shall accurately control flow, independent of system pressure fluctuation.
- 1.4. Maximum flow setting shall be adjustable to 41 different settings within the range of the valve size.
- 1.5. Valve housing shall be permanently marked to show direction of flow.

2. VALVE ACTUATOR

2.a. FlowCon FT actuators

- 2.a.1. Actuator housing shall be rated to IP54, including upside-down mounting.
- 2.a.2. Actuator shall be driven by 24V or 230V AC, and shall depending on actuator choice accept 0-10V DC or ON/OFF control signal.
- 2.a.3. Actuator shall use full stroke and provide full authority.
- 2.a.4. Actuator shall have visible indication of stroke position.
- 2.a.5. Failsafe function shall be available on all version.

OR....

2.b. FlowCon FN actuators

- 2.b.1. Actuator housing shall be rated to IP54. 360° mounting shall be acceptable, IP40 at 180°.
- 2.b.2. Actuator shall be driven by 24V AC/DC or 110V/230V AC, and shall depending on actuator choice accept 0(2)-10V DC, 3-point floating or 2-position control signal.
- 2.b.3. Actuator shall use full stroke and provide full authority.
- 2.b.4. Actuator shall have visible indication of stroke position.
- 2.b.5. Feedback signal equal to control signal shall be standard on modulating versions.
- 2.b.6. Failsafe version shall be available for 24V AC/DC signal.
- 2.b.7. Optional auto stroke function shall be available on modulating version.
- 2.b.8. Electrical override shall be possible.

3. VALVE HOUSING

3.a. FlowCon A

- 3.a.1. Valve housing shall consist of forged brass ASTM CuZn40Pb2, rated at no less than 2500 kPa (360 psi) static pressure at +120°C (+248°F).

OR....

3.b. FlowCon AB

- 3.b.1. Valve housing shall consist of forged brass ASTM CuZn40Pb2 or DZR ASTM CuZn36Pb2As, rated at no less than 2500 kPa (360 psi) static pressure at +120°C (+248°F).
- 3.b.2. Pressure/temperature test plugs for verifying accuracy of flow performance shall be available for all valve sizes.

OR....

3.c. FlowCon ABV

- 3.c.1. Valve housing shall consist of forged brass ASTM CuZn40Pb2, rated at no less than 2500 kPa (360 psi) static pressure at +120°C (+248°F).
- 3.c.2. Valve ball shall consist of chemically nickel-plated brass (ASTM CuZn40Pb2).
- 3.c.3. Pressure/temperature test plugs for verifying accuracy of flow performance shall be available for all valve sizes.

4. FLOW REGULATION UNIT

- 4.1. Flow regulation unit shall consist of glass-reinforced PSU/POM/PPS with an EPDM diaphragm (20 mm / 3/4" insert) or a hydrogenated acrylonitrile-butadiene-rubber diaphragm (40 mm / 1 1/2" insert).
- 4.2. Flow regulation unit shall be readily accessible, for change-out or maintenance. Flow regulation unit shall be adjustable with the valve in-line and the system in operation.
- 4.3. Flow regulation unit shall be externally adjustable to 1 of 41 different flow rates without limiting the stroke length; shall be available in 3 different operational pressure ranges for DN15/20/25 (1/2", 3/4", 1") and 1 operational pressure range for DN25/32/40 (1", 1 1/4", 1 1/2"); minimum range shall be capable of being activated by 16 kPaD (2.3 psid). Further, the flow regulation unit shall be capable of controlling the flow within ±10% of rated flow or ±5% of maximum flow.

APPLICATION AND SCHEMATIC EXAMPLE

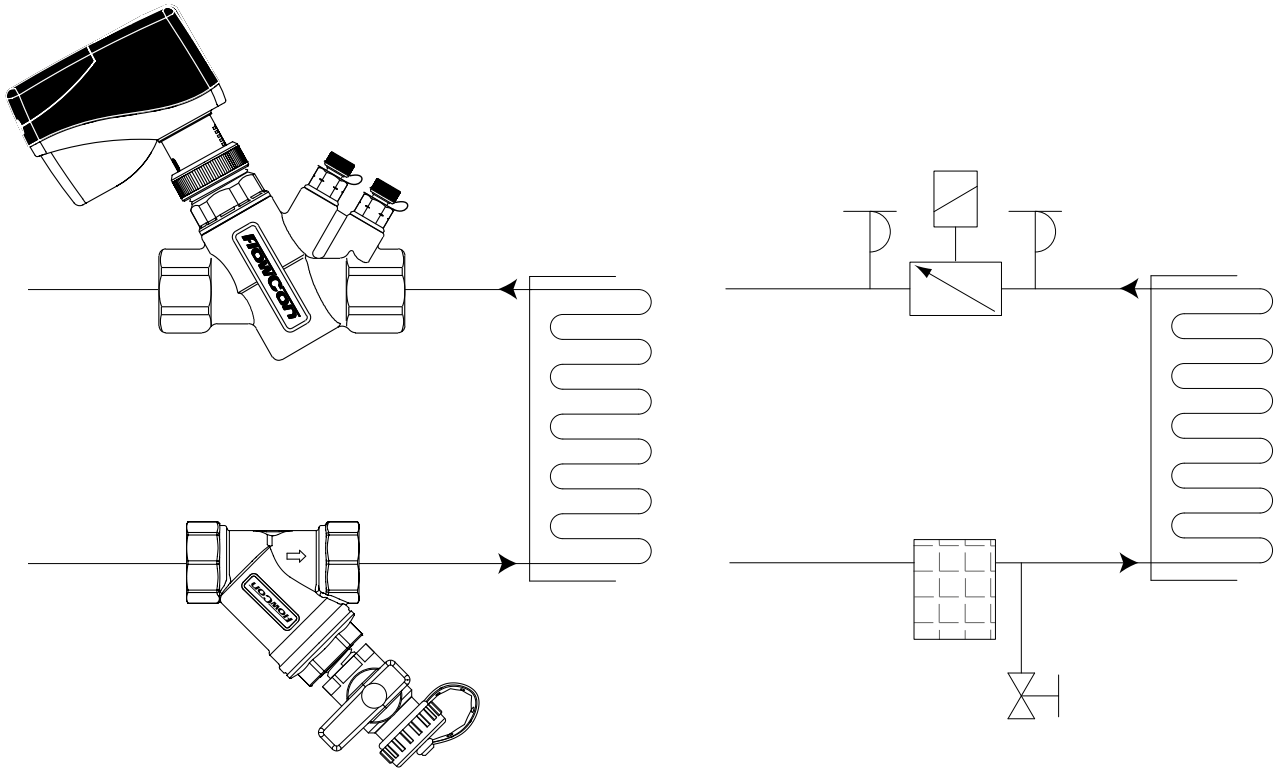

UPDATES

For latest updates please see www.flowcon.com

FlowCon International can accept no responsibility for possible errors in any printed material.
All rights reserved.