

AQS-KAM-xx, AQS 71-KAM-T, AQS-KAM-RH-V CO2 TEMPERATURE TRANSMITTERS

PRODUCT DATA & INSTALLATION INSTRUCTIONS



FEATURES

- Calibration-free technology
- Outstanding long-term stability
- Maintenance free
- universal mounting flange

SPECIFICATION

Power supply	24 Vac, ±20% (SELV) 15...35 Vdc
Power consumption	0.6 W
Max. current consumption	0.35 A (0.3 sec / 15 sec)
Ambient Limits	
Operating temperature	-20...+60 °C (-4...+140 °F)
Transport and storage	-20...+60 °C (-4...+140 °F)
Humidity	0...95% rh, non-condensing

Safety

Protection class	III as per EN 60730-1
Protection standard	Housing IP65 as per EN60529 Probe IP20
Housing material	Flame retardant V0 as per UL94
Housing	plastic (PC)
Dimensions	see Fig. 1 on page 3
Mounting	duct, M16x1,5 cable inlet

CO₂ Sensor

Output signal	0...10 V
Output current	-1 mA < I _L < 1 mA
Output scaling	0...10 V = 0...2000 ppm CO ₂

Accuracy (CO ₂ at 25 °C [77 °F], 1013 mbar)	0...2000 ppm < ± (50 ppm + 2% of m.v.)
--	--

Temperature stability:	typ. ± (1 + CO ₂ conc. [ppm] / 1000) ppm / K (-20 ... +45 °C)
------------------------	--

Response time	τ ₆₃ < 100 sec at 3 m/s
Warm-up time	< 5 min

Temperature

Output signal	0...10 V
Output Current	-1 mA < I _L < 1 mA
Output scaling	0...10 V = 0...50 °C
Accuracy (20 °C [68 °F])	± 0.3 K
Response time	τ ₆₃ < 50 sec. at 3 m/s
AQS-KAM-RH-V	τ ₆₃ < 60 sec. at 3 m/s

GENERAL

The AQS Temperature Transmitters set new standards in CO₂ measurements in HVAC applications. Operation is based on the infrared principle. A calibration-free procedure compensates for aging of the infrared source and ensures outstanding long-term stability. The AQS provide 0...10 V analog output for CO₂ and temperature and are designed for HVAC applications (contact Honeywell for special applications). They are suitable for direct wiring with universal and voltage-controlled inputs. Additionally, the AQS-KAM-xx Temperature Transmitters feature a built-in passive temperature sensor. The AQS-KAM-RH-V Temperature Sensor is equipped with a relative humidity sensor. See also following table.

Table 1. List of devices

OS number	CO ₂ + temp. output	temp. output (passive)	rel. humidity output
AQS-KAM-00		Pt1000	--
AQS-KAM-01		Ni1000	--
AQS-KAM-10	0...10 V	NTC10kΩ	--
AQS-KAM-20		NTC20kΩ	--
AQS 71-KAM-T		--	--
AQS-KAM-RH-V		--	0...10 V

NOTE: Avoid strong mechanical stress and improper handling. The cable gland and housing cover must be screwed tightly against gas penetration, to avoid incorrect measurements.

Table 2. Troubleshooting

Error	Possible cause	Remedies
Unrealistic results	Skewed installation	Air inlet and probe tip must be perpendicular to air flow.
	Low air velocity	Air velocity must be > 1 m/sec (200 ft/min).
	Housing not tight	Seal cover and gland tightly.
Long response time	Contamination of sensor or probe	Check sensor and probe for soiling and clean, as necessary.

Passive Temp. Sensors (AQS-KAM-xx)

Output 2-wire
 Wire resistance (typ.) 0.4 Ω (terminal-sensor)

NTC10kΩ

Nominal value 10kΩ ±0.5% at 25 °C
 Accuracy ±0.2 °C at 25 °C
 Response time (typ.) $t_{63} < 120$ s at 3 m/s air velocity
 Sensitivity (typ.) -440 Ω / K at 25 °C (non-linear)

NTC20kΩ

Nominal value 20kΩ ±0.5% at 25 °C
 Accuracy ±0.2 °C at 25 °C
 Characteristic NTC20kΩ (see EN0B-0476GE51)
 Response time (typ.) $t_{63} < 120$ s at 3 m/s air velocity
 Sensitivity (typ.) ≈ -934.5 Ω / K at 25 °C (non-linear)

Ni1000

Nominal value 1000 Ω at 0 °C
 Accuracy ±0.4 °C at 0 °C
 Characteristic DIN 43760
 Sensitivity (typ.) ≈ 6.18 Ω / K

Pt1000

Nominal value 1000 Ω at 0 °C
 Accuracy (IEC751 Cl. B) $0.3 + 0.005 * |t|$ at 0 °C
 Characteristic see EN0B-0476GE51
 Sensitivity (typ.) ≈ 3.85 Ω / K

Relative humidity (AQS-KAM-RH-V)

Working range 0...95% RH, non-condensing
 Output 0...10 V prop. to 0...100% RH
 Accuracy at 20 °C typ. ±2% RH, max. ±3% RH in range of 20...80% RH

*Temperature / relative humidity / CO₂ accuracy may differ, depending on various environmental conditions (e.g., air velocity or temperature difference between the air temperature and the ambient temperature).

WIRING

wiring run	maximum length
sensor to controller	200 m (660 ft)

NOTE: Installation of the sensor near high EMI-emitting devices may lead to faulty measurements. Use shielded wiring in areas with high EMI. Keep 15 cm (5.9") min. distance between sensor lines and 230 Vac power lines. Use two transformers: one for sensors and actuators and one for the controller.

DIMENSIONS

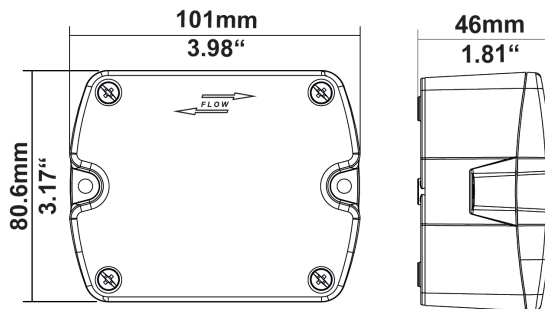
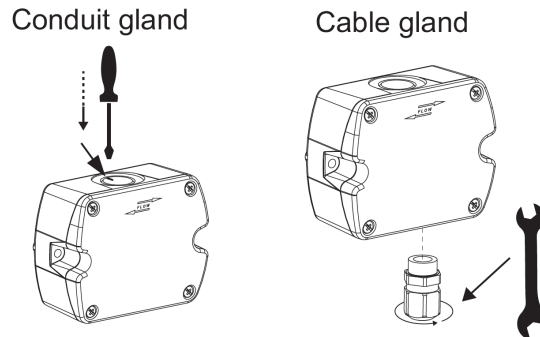

Fig. 1. Housing dimensions (mm)

MOUNTING



Screw with torque of 1.5 Nm for break-through. Recommended tightening torque: 3.5 Nm.

Fig. 2. Assembly of conduit / cable gland

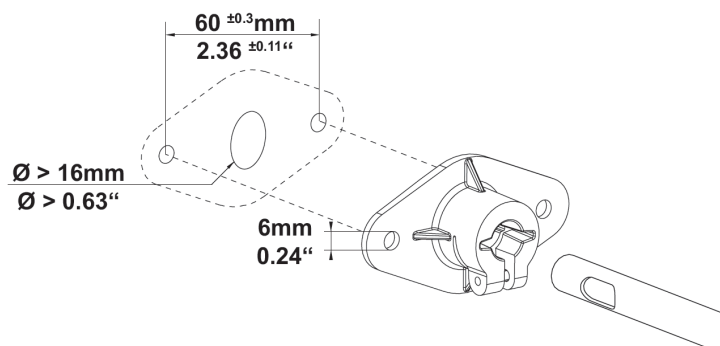

Fig 3. Flange mounting on duct

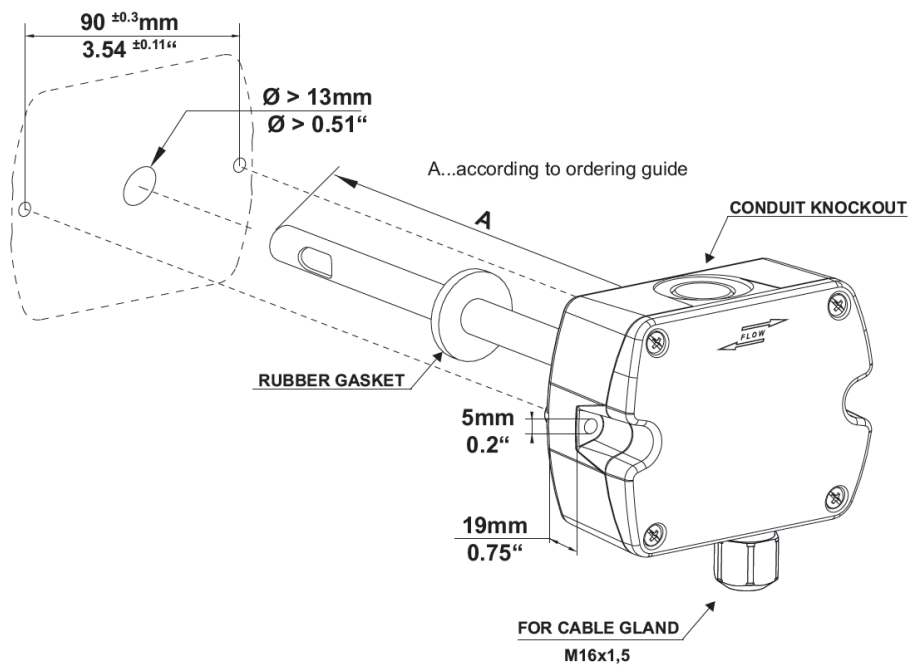

Fig. 4. Direct mounting on duct (probe length A = 200 mm)

WIRING

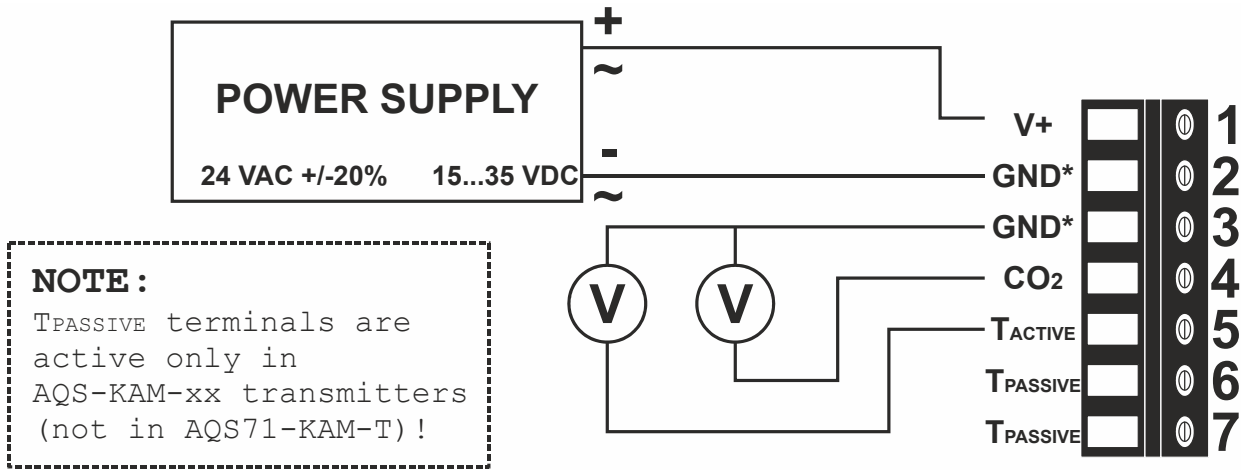

Fig. 5. Wiring diagram for AQS-KAM-xx and AQS71-KAM-T (not AQS-KAM-RH-V)

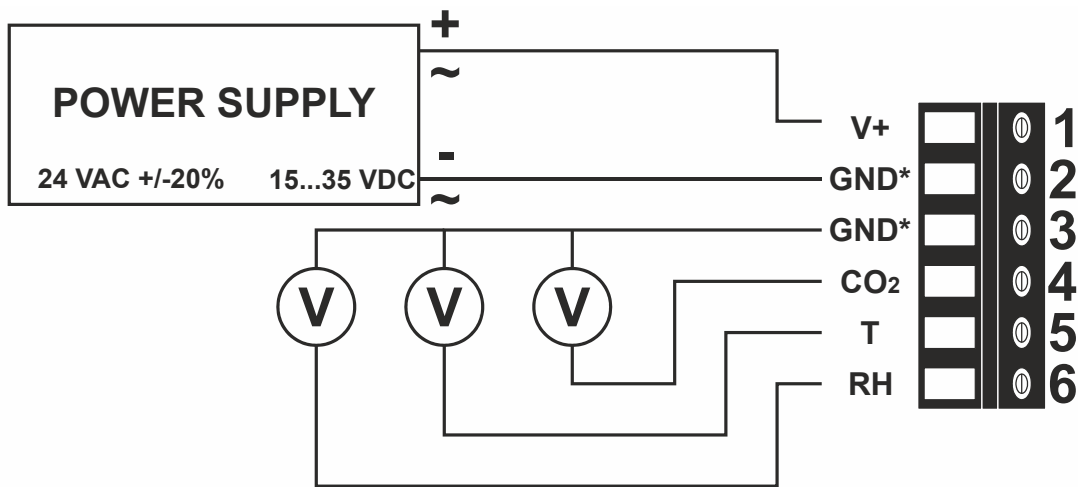

Fig. 5. Wiring diagram for AQS-KAM-RH-V

IMPORTANT

For failure-free operation and performance according to specifications, it is essential that the supply GND and the measurement GND be wired separately!

Honeywell
THE POWER OF CONNECTED

Manufactured for and on behalf of the Environmental & Energy Solutions Division of Honeywell Technologies Sàrl, Rolle, Z.A. La Pièce 16, Switzerland by its Authorized Representative:

Home and Building Technologies

Honeywell GmbH
Böblinger Strasse 17
71101 Schönaich, Germany
Phone +49 (0) 7031 637 01
Fax +49 (0) 7031 637 740
<http://ecc.emea.honeywell.com>

EN1B-0377GE51 R0518F

Subject to change without notice